

WOODBURY PARISH COUNCIL

Wednesday 23rd September

Minutes of a meeting of Woodbury Parish Council, held remotely via Zoom, on Monday, 21st September 2020 at 7.30 pm.

Present: S Andrews, R Ball, P Bricknell, R Cullen, M Hesketh, P Jordan, G Jung, Mrs C McGauley (Chairman), G Murrin, R. Parr and J Pyne.

20/89	Public Session: <i>No Comments were made.</i>
20/90	APOLOGIES: Cllr D Atkins.
20/91	DECLARATIONS OF INTEREST: <i>None.</i>
20/92	MINUTES: The Minutes of the Meetings held on 10 th August and 7 th September 2020 confirmed as a correct record. AIF.
20/93	FLOOD CONSULTATION: Cllr G Jung explained Devon's Updated Local Flood Risk Management Strategy Consultation Document was now available for public consultation. It was agreed that Cllrs G Jung, R Ball and P Jordan will help draft a WPC response.
20/94	NEW PLANTATION FENCING: RESOLVED. The quotation from Countrywise Contractors accepted. AIF.
20/95	SAFETY BARRIER CHURCHSTILE LANE: RESOLVED. The quotation, set out below. Accepted. AIF.

WOODBURY PARISH COUNCIL

20/96	<p>PLANNING:</p> <p>EXTON 20/1904/FUL Proposed annex accommodation Exton Mill Lane Exton Exeter EX3 0PH. NOT SUPPORTED. Not an annex but an unconnected separate entity. Building in the open countryside. AIF. 2 abstentions.</p> <p>WOODBURY 20/1946/TCA T1 - Maple, Dismantle in sections to near ground level T2 - Cherry, Fell to near ground level T3 - Robinia, Dismantle in sections to near ground level Reason for works: T1 is showing significant basal decay and cavity, concerns over stability of tree due to it's exposed location. T2 is growing within the canopy of T1 and has bad form, will be left exposed when T1 is removed. T3 has had a large stem removed and now has decay present at the base of the tree along with a potentially weak basal union. Dieback present within crown of tree, limited life expectancy. Gilbrook House Woodbury Exeter EX5 1LG. SUPPORT. AIF.</p> <p>WOODBURY SALTERTON <i>None.</i></p>
20/97	COUNCILLORS' QUESTIONS: <i>None.</i>

Meeting closed 8.15 pm

WOODBURY PARISH COUNCIL

Cust. Name WOODBURY PARISH COUNCIL
 Address GREENSIDE
WOODBURY
EXS 1LP

**CountryWise
Contractors**

Telephone No. _____
 Email Address _____

NO. **0006**

ESTIMATE

QUOTATION

WORKS AT PLANTATION - PARKHAYES

Description	Price
SUPPLY AND FIT BIRDS MOUTH FENCING - 27 METRE	
POSTS 100 x 150 x 1500mm	
RAILS 100 x 100 x 3mm	
HIGHT OUT OF GROUND 800mm	
POST CENTRES 1.5m	
ERECTED WITH SOFT WOOD POSTS	£900.00
OR	
ERECTED WITH OAK POSTS	£1,200.00
Total (€)	

Tel 07836 552931 www.countrywisecontractors.co.uk

WOODBURY PARISH COUNCIL



QUOTE

Woodbury Parish Council
Greenway
Woodbury
EXETER
Devon
EX5 1LP
GBR

Date
10 Jun 2020

Quote Number
QU-0047

Reference
MRBWS-SFC

Woodbury Property &
Plumbing Maintenance,
7 Furze Road Woodbury
Exeter Ex5 1PF
Email
cdp77@btinternet.com
Mobile 07855 527124
Office 01395 233747

Description	Quantity	Unit Price	Amount GBP
Birds Mouth Fencing for New Plantation Woodbury Salterton.	1.00	2,027.87	2,027.87
Supply and erect 30 linear meters coverage of 150mm x 100mm posts and 100mm x 100mm rails, dig out all old broken off posts and erect new posts dug into the ground and concreted into place install 100mm x 100mm rails into birds mouth posts.			
Total for all above materials supplied, waste removal for environmental recycling and labour.			
		Subtotal	2,027.87
		TOTAL NO VAT	0.00
		TOTAL GBP	2,027.87

WOODBURY PARISH COUNCIL

David Embley

The Willows

157 Hulham Road

Exmouth

EX8 4QZ

07927 115870

Quotation for fitting of Birds Mouth Fencing, New Plantation, Woodbury Salterton.

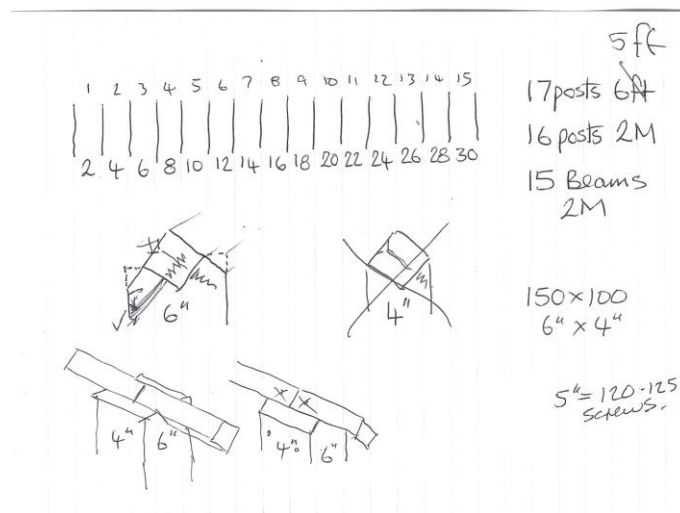

Material options:

Iroko hardwood uprights with US Redwood softwood rail: £1,057

All US Redwood softwood: £402

Labour: £800 including site clearance

No VAT will be added.

WOODBURY PARISH COUNCIL

David Embley

The Willows

157 Hulham Road

Exmouth

EX8 4QZ

07927 115870

Quotation for fitting new safety barrier Churchstile Lane, Woodbury.

Fit one Anavio Metal Fencing 1830mm GAP x 812mm H Galvanised Iron Fence Railing ABZP01 plus posts:



Railing & posts	£153
Tarmac & postcrete	£109
Labour	£200
Total	£462

No VAT will be added.